CP
.....
550 



TEST PROJECTOR

USER'S MANUAL

8. Introduction

This manual provides information on the procedures to be implemented to ensure adequate and optimal operations of your CP550test projector.

Before conducting any tests and/or calibrations, please read the instructions carefully. This document serves as both a reference guide and user's manual, be sure to keep it handy at all times.

The information presented in this document is not contractually binding and has been provided for reference purposes only. It may be modified without prior notification. A document of this type might contain errors or omissions, despite all the efforts undertaken to avoid such an eventuality. Under no circumstances can ESSILOR be held liable for operating flaws potentially resulting from said errors or omissions.

8.1. Installation precautions





- When your CP550 is not in use, be sure to protect it with the cover provided.
- Abide by all use and storage conditions within the following ranges:
 - Use:
 - Temperature: +10 °C to +40 °C
 - Relative humidity: 30% to 85%
 - Storage:
 - Temperature: -10 °C to +55 °C
 - Relative humidity: below 70%
- Always prevent condensation from forming.
- When using or storing the device, place it in a safe and stable location. Avoid places that are exposed to dust, gas, salt or sulfur.
- Do not set up the CP550 near any explosive or flammable substance.
- Protect the device from all vibrations and shocks.
- Whenever moving the projector, be sure to protect it from shocks by using the original packaging.
- Never place flammable objects on top of the CP550, as fire could break out.
- Before discarding the product packaging, sort the various materials and proceed in compliance with national or local legislation.
- Do not touch any of the optical parts due to the risk of irreversibly impairing calibration accuracy.
- Insert the power supply plug into both the socket and device tightly. The projector must, without exception, be connected to an electrical power network with a ground.
- When moving the CP550, first turn off the power switch then unplug the electrical cable.
- When turning the projector lamp on, never look through the projector lens.

8.2. Safety guidelines

Caution:

- Should you notice something abnormal (noise or smoke), immediately unplug the power supply cable and contact your retailer. In continuing to use the device under such conditions, you run the risk of starting a fire or causing physical damage.
- In the event of malfunction, never attempt to undertake repairs on your own. Contact your retailer.
- Do not reverse the (+/-) polarity of the batteries.
- Never throw a battery into a fire and never try to charge it or heat it.
- Do not combine new and used batteries or batteries of different brands, so as to avoid the risk of battery leakage, overheating or explosion.
- When discarding a battery, always comply with the regulations in effect in your country of residence.
- Ensure that the power supply cable is always clean, free of dust or grease and showing little or no wear. A dirty or worn cable connection may lead to poor operating performance or even fire.
- Never touch the plug prong with wet hands, as this could cause an electrical discharge or bodily injury.
- Never immerse the power supply cable or pour water on it.

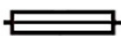
8.3. Symbols

	This device corresponds to the EN60601-1 B type of equipment.
	Model year (4-digit year)
	Special collection for this type of electrical and electronic device
	Fuse
	Caution: Read and apply the accompanying written materials (use instructions, etc.)
	Switch in the "off" position
	Switch in the "on" position

9. General description

Open the product packaging carefully to avoid damaging the instrument and its accessories.

Check that each of the following accessories has been included and exhibits no damage.

9.1. Standard accessories

- Projector..... 1
- Screen..... 1
- Power supply cable..... 1
- Calibration sheet..... 1

- Test card..... 1
- Protective cover..... 1
- Fuse (250V, 2AT)..... 2
- Remote control..... 1
- Alkaline battery SUM4..... 4
- Hex head key (5 mm)..... 1

9.2. Optional accessories

- Stand
- Wall mounting assembly
- Projector arm (without rotation)
- Projector arm (with rotation)
- Polarized filter
- Red-green peephole

9.3. Display

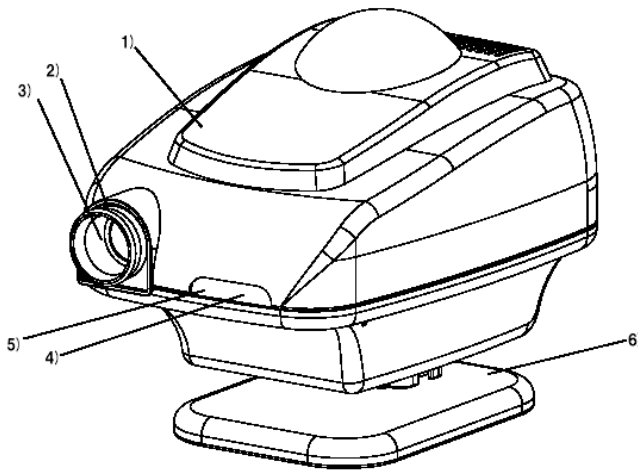

- 1) Upper cap
- 2) Focus ring
- 3) Lens
- 4) Infrared receiver
- 5) Pilot light
- 6) Stand

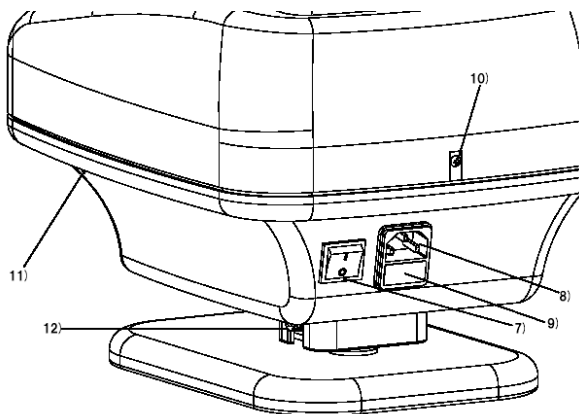

- 7) Main switch
- 8) Electrical socket
- 9) Fuse holder
- 10) Cap clamping screw
- 11) Brightness setting
- 12) Side screw to fasten the projector

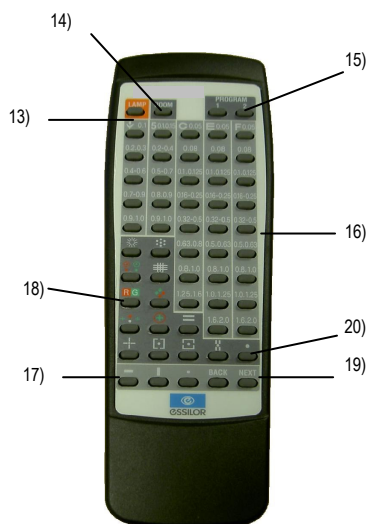

- 13) LAMP: Lamp activation
- 14) ROOM: Room light activation
- 15) PROGRAM: Program (1,2)
- 16) Tests
- 17) Masks
- 18) Red-green filter
- 19) Program scrolling
- BACK
- NEXT
- 20) Confirmation button

10. Installation

10.1. Projector installation

Fasten the projector connector to the ball joint on the stand as indicated, then tighten the side screw (12) using the hex head key. If the connector has not been appropriately fastened, the projector could suddenly swivel and cause injury.

10.2. Electrical power supply

Connect the power supply cable to the electrical socket (8) and then to the wall outlet (AC).

10.3. Remote control

Remove the cap from the battery compartment of the remote control unit. Load two SUM4 batteries in respecting the + and - markings.

10.4. Screen set-up

Insert the cable supplied with the device into the two ports located on top of the screen, then tie the two ends.

Fasten a hook into the wall at the height of the patient's point of observation, then hang the screen horizontally.

The presentation distance must lie between 2 and 7 meters.

- △ If you are not using the standard screen included with the projector, you will not be able to obtain the same performance as with the original diagnostic equipment.
- △ The projection must be made on the smooth and shiny side.

10.5. Projection focusing

6- The projector and patient must be positioned the same distance from the screen.

- △ When changing projection distance, the size of the vision test types (or optotypes) automatically varies to ensure constant compliance with optotype presentation standards.

- 7- Turn the main switch **(7)** on.
- 8- Press the *0.1 Test* button (Landolt or Snellen) on the remote control.
- 9- Loosen the side screw **(12)** during calibration and then adjust the projector angle such that the test is positioned in the middle of the screen.
- 10- Turn the focus ring **(2)** in order to complete focusing on the 0.1 test by use of the calibration sheet provided with the projector. Move the CP550 either forwards or backwards so that the test size is identical to the size of the calibration sheet.

10.6. Brightness setting

- 5- Turn the main switch **(7)** on.
- 6- Insert a narrow screwdriver (length: 6 cm or more) into the brightness setting port **(11)** to press the button. A signal then sounds 3 times.

The orange diode lights up and Landolt's 0.05 test is displayed.

- 7- Press either the "BACK" or "NEXT" button on the remote control to adjust brightness.

△ Initial setting: 200~250 Cd/m² (5 m).

△ Possible setting according to the ISO standard: 80 ~ 320 Cd/m².

- 8- Press the Lamp button **(13)**. The signal again sounds three times. The brightness setting is now memorized by the machine.

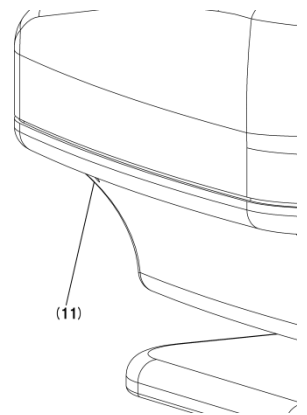

11. Use conditions

- If you are using the device continuously, both the lens and projector could heat up, increasing the chance of being burned.
- If the device is submitted to a shock or vibrations while in use, both the mask and test might move and no longer be projected accurately. In this case, turn the switch off and back on. The mask and test are once again projected normally.
- The remote control uses infrared rays. If another device is running at the same time on other infrared rays, the CP550 might not operate normally. Should several test projectors be used in the same eye examination room, please contact your retailer.
- If the remote control remains idle for 5 minutes, the lamp automatically turns off. To turn it back on, simply press the LAMP button on the remote control.

11.1. General uses

- 5- Place the switch **(7)** into the "I" position in order to turn the projector on.
- 6- Select a test to activate lighting of the lamp. The 37 tests can be selected by pressing keys **(16)**. Vision acuity levels are displayed to within tenths on both sides of the mask.
- 7- Through use of the key **(18)**, you can superimpose a red/green filter onto the morphoscopic acuity levels.
- 8- A complete row or a specific optotype may be isolated using the keys **(17)**. Activating the "BACK" and "NEXT" buttons allows moving this mask onto the projected test.

- △ Whenever applying a mask to either the first or last element of a test, the device makes the transition to the previous or subsequent test and then applies the mask to either the first or last element of this new test.

11.2. Program mode

11.2.1. Recording a program

6- Hold the "PROGRAM 1" or "PROGRAM 2" button **(15)** down for at least 5 seconds.

A signal rings three times, and the device projects the first recorded test and mask pair. The test is projected if no test had been previously recorded.

- △ If the "Automatic stop" function has been activated, start by pressing the LAMP button for a test to appear, then hold the "PROGRAM" button down for at least 5 seconds.

7- Use the remote control in order to project the test or mask that you would like to store in memory.

8- Press the LAMP button to memorize the displayed test or mask.

9- The sound signal rings one more time and either the test or memorized test is displayed. Repeat steps 2 and 3.

- △ You can record up to 48 different tests. Beyond this number, a signal will ring twice and the projector will indicate that it is unable to enter any more recordings.

10- To memorize your programming sequence, press either the "PROGRAM 1" or "PROGRAM 2" button **(15)**, depending on what you selected in step 1.

A signal sounds three times. The recording is now completed. The memorized program is saved even if the device has been turned off.

Special manipulation

→ To return to the first test: press **(20)** followed by the "NEXT" button **(19)**.

→ To return to the last test: press **(20)** followed by the "BACK" button **(19)**.

→ To delete all recorded tests: press **(20)** followed by the "LAMP" button **(13)** held down for 5 seconds. A signal will ring three times.

- △ The "Automatic stop" function remains inactive when entering a program.

11.2.2. Working in Program mode

3- Press the "PROGRAM 1" or "PROGRAM 2" button **(15)**.

The device projects the first recorded test and mask pair.

- △ If the "Automatic stop" function has been activated, start by pressing the LAMP button.

4- Press the "NEXT" button **(22)** to project the next recorded test or mask, or press the "BACK" button **(21)** to project the previous test or mask.

- △ If the test or mask happen to be the first ones, a signal will ring twice and the device will indicate the impossibility of shifting any further back.

- △ If you press the Test/Mask button, the Program mode will stop and the device will return to normal mode. It will also stop if the LAMP button is pressed.

△ After an automatic stop, the device returns to normal mode.

12.Storage and maintenance

12.1. Handling the device

- When the projector is not in use, protect it with the cover provided by the manufacturer.
- Do not touch any of the optical parts with your fingers and avoid exposing any parts to dust. The dust accumulated on any optical part of the device is to be removed using a brush or a bellows. Should you notice a finger smear or trace of grease on an optical part, apply an alcohol-based cleanser and wipe with a lens cloth or gauze.
- If the projector surfaces are dirty, take the precaution of cleaning them with a dry cloth. For marks that are difficult to remove, we recommend using a damp cloth or neutral detergent.
- △ Avoid employing organic solvents as these would damage the paint coating of the device.
- If the projector remains idle for awhile, unplug the power supply cable.
- Also, if the projector remains idle for awhile, remove the batteries from the remote control.

12.2. Replacing a fuse

- 3- Unplug the power supply cable (8) to avoid any risk of electrical discharge.
- 4- Remove the fuse holder (9), then replace the fuse.
- △ If you are not using the appropriate fuse, the device will tend to easily malfunction or potentially cause an accident. Only use the prescribed fuse (250 V, 2 AT).
- △ The fuse holder contains two fuses. Since you cannot visually identify the defective fuse, remove both and test them individually.
- △ Anticipate other problem sources should the device continue to malfunction following replacement of the fuse. Immediately unplug the power supply cable and contact the closest product retailer.

12.3. Replacing batteries on the remote control

Pull on the battery compartment lid, then remove the used batteries and replace them with new ones. Position the new batteries as indicated on the sticker at the bottom of the battery compartment. Use two non-corrosive batteries in order to avoid leaks (x 2 UM-4 alkaline batteries).

13.Trouble-shooting

Be sure to check each of the following elements before bringing the device in for repairs. If, once these elements have been verified, the instrument is still not functioning properly, contact your product retailer.

4- *The lamp does not light up when the main switch (7) is turned on.*

Cause 1: Poor connection of the power supply cable

→ Place the switch on the "0" position and then firmly plug in the power supply cable (8).

Cause 2: The fuse has blown.

→ Replace the fuses (see 5.3 – *Replacing a fuse*).

5- *Imbalanced brightness within the field of vision.*

Cause 1: The optical part or test is dirty.

→ Clean the optical part or test (see 5.1 – *Handling the device*)

Cause 2 : incorrect sitting of the LED position :

→ Adjust the position of the LED using a screwdriver

6- *The projector does not react when pressing on the remote control buttons.*

Cause 1: Depleted batteries

→ Replace the batteries (see 5.4 – *Replacing the batteries*).

14. Technical characteristics

14.1. Projector

- Projection distance: 2.0 ~ 7.0 m
- Projection enlargement: x 30 (for a 5-m projection distance)
- Projection field: 335 x 222 mm (for a 5-m projection distance)
- Brightness: 80 ~ 320Cd/m² (200Cd/m² for a 5-m projection distance)
- Test/mask selection speed: 0.3 seconds
- Program: 2 types (48 tests or masks)
- Angle of inclination: ± 10°
- Dimensions: 248 mm (l) x 336 mm (w) x 234 mm (h)
- Weight: 4.5 kg
- Automatic stop mode: 5 minutes
- Electrical power supply: 100 ~ 240V
- Electrical consumption: 60 VA
- I B category
- Compliant with the EMC standard IEC60601-1-2
- EC compliance certification

14.2. Remote control

- Type of control: wireless
- Dimensions: 62 mm (l) x 193 mm (w) x 26 mm (h)
- Weight: 100 g

14.3. Tests

- Total number of tests: 50 different kinds

- Visual acuity of between 1/20 and 20/10
 - Letters, Landolt rings and Snellen "E" chart: logarithmic scales,
 - Numerals and morphoscopic optotypes: decimal scales.
- Specific tests:
 - Polarized binocular vision tests: stereoscopy, heterophoria, aniseikonia, binocular and biocular balance (duochrome, double row of numbers),
 - Tests of astigmatism: Parent dial, shot test, crosshairs,
 - Other: point light source, Worth test.
- Filters:
 - Duochrome
- Mask:
 - Vertical and horizontal lines,
 - Isolated optotype.

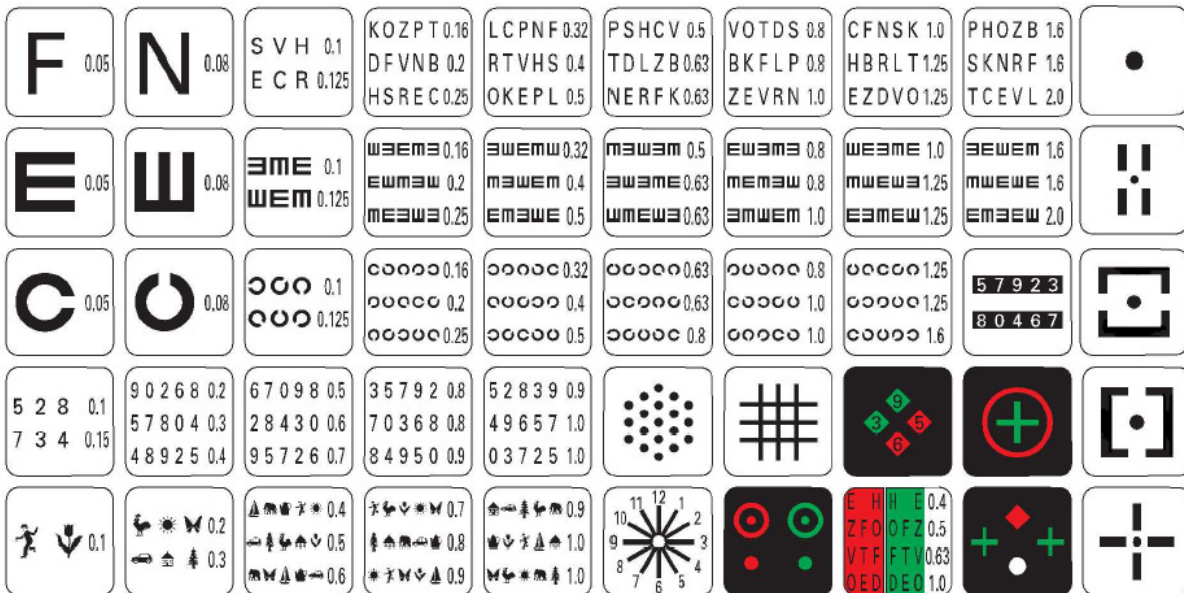

Instrument's range CP550 (CP550EA, CP550EB, CP550SB) can all be connected to APH 550.



Essilor Instruments USA
8600 W. Catalpa Avenue, Suite 703
Chicago, IL 60656
Phone: 855.393.4647
Email: info@essilorinstrumentsusa.com
www.essilorinstrumentsusa.com